

**MACK**®

Built for  
growth.



## **MACK MD6**

Dependability, durability and steadfast support — everything you've come to expect from Mack is now available in a medium-duty truck: the Mack MD Series. The MD Series is packed from the exterior to the driver environment with features that ensure a smooth, stress-free ride, backed by our unmatched local dealer support when you need it. We've taken care of the details so you can focus on growing your business.

Max GVWR

**25,995**

LBS

Power

**300**

MAX HP

Peak Torque

**660**

LBS.-FT. MAX

**MD SERIES**

## Key Features

Cab air suspension (standard)

34-inch assembled frame width (standard)

Air suspension driver's seat (standard)

Flat-bottom steering wheel (standard)

Power windows and locks (standard)

Passenger door lower peep window (standard)

Full-width aluminum grated steps for easy entry and egress, horizontally offset for visibility (standard)

Rear leaf spring suspension (standard), Mack Maxlite AirRide (optional)

Clear back-of-cab and frame and side frame space for easy body installations (standard)

50-gallon fuel tank (standard), 90-gallon (optional)

Tires 11R22.5 (standard), 255/70R22.5 Low Profile tires (optional)

8 wheelbases to accommodate bodies of various lengths and types

Frame rails with 110,000 PSI yield strength (standard)

Steel, white powder coated disc wheels (standard), aluminum wheels (optional)



### Comfortable Interiors

The Mack MD Series brings heavy-duty levels of driver comfort and functionality to medium-duty trucks, to keep drivers comfortable and safe all day. Tilt/telescoping steering column, air-suspension driver's seat and controls within easy reach place comfort where it counts.

### All Day Uptime

MD Series customers have access to Mack's industry-leading uptime services. Mack's ASIST platform streamlines and shares service communications between the customer, dealer and Mack's 24/7 Uptime Center. The available Geotab® feature provides basic telematics and is upgradeable for enhanced fleet management.

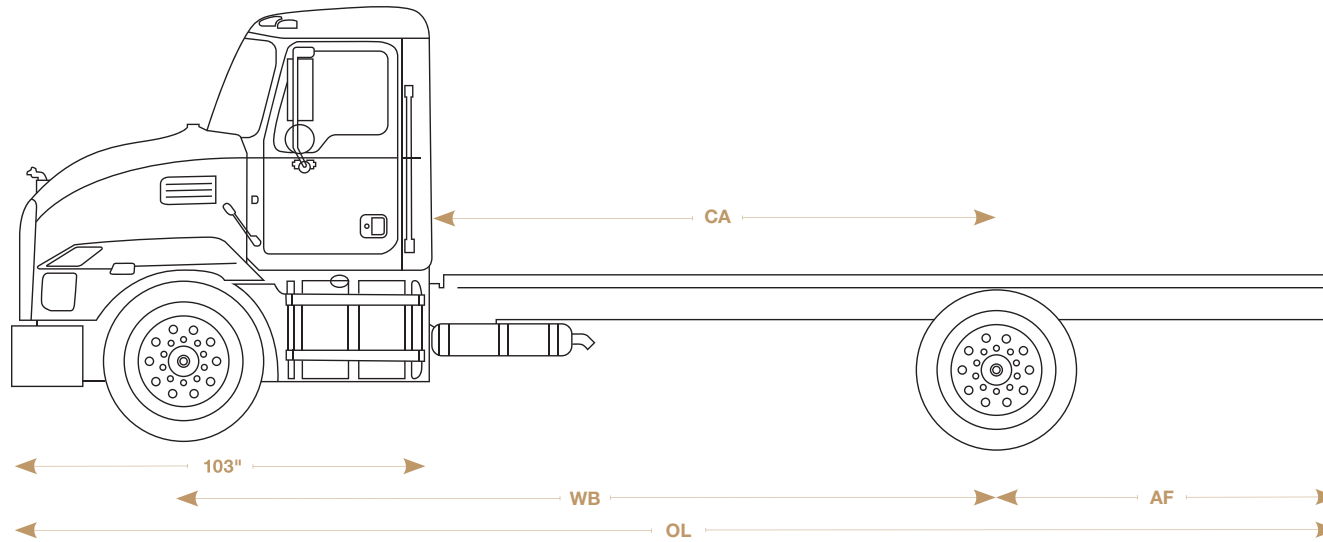

Typical Dry Van Body Length	(ft.)	10	12/14	16	18	20	22	24	26/28*
Wheelbase*	WB (in.)	150	166	186	206	221	236	251	270
Cab to Rear Axle	CA (in.)	87	103	123	143	158	173	188	207
After Frame	AF (in.)	50	55	60	65	70	80	90	100
Overall Length Chassis	OL (in.)	240	261	286	311	331	256	381	410
GVWR**	(lb.)	25,995	25,995	25,995	25,995	25,995	25,995	25,995	25,995
Front Axle Capacity (std.)	(lb.)	10,000	10,000	10,000	10,000	10,000	10,000	10,000	10,000
Rear Axle Capacity (std.)	(lb.)	17,000	17,000	17,000	17,000	17,000	17,000	17,000	17,000
Front Axle Weight**	(lb.)	6,080	6,080	6,225	6,225	6,320	6,400	6,390	6,420
Rear Axle Weight**	(lb.)	3,455	3,455	3,410	3,410	3,435	3,515	3,450	3,500
Total Chassis Weight***	(lb.)	9,535	9,535	9,665	9,665	9,750	9,915	9,840	9,920

\*Wheelbase selection should be based on specific weight distribution.

\*\*Base model GVWR, ratings and chassis weights.

\*\*\*Total Chassis Weight estimate is for standard specifications excluding driver and fuel.

<b>ENGINE</b>	Cummins® B6.7 Inline 6-cylinder, Turbo/Intercooled Diesel	
<b>HP/Torque</b>	220 hp/600 lb. ft. EPA (std)/CARB (opt) 240 hp/560 lb. ft. EPA (std)/CARB (opt) 250 hp/600 lb. ft. EPA (std)/CARB (opt) 260 hp/660 lb. ft. EPA (std)/CARB (opt) 280 hp/660 lb. ft. EPA (std)/CARB (opt) 300 hp/660 lb. ft. EPA (std)/CARB (opt)	
<b>Air Cleaner Type</b>	12 in.	
<b>Alternator</b>	Delco-Remy® 12V, 160 amp	
<b>Batteries</b>	Dual 760 CCA (1520 total CCA)	
<b>Engine Brake</b>	Cummins®, with dash switch	
<b>Fuel Filter</b>	Filter and water separator	
	Heated, fuel and water separator	
<b>Starter</b>	Melco 12V	
<b>TRANSMISSION</b>	<b>STANDARD</b>	<b>OPTION</b>
	Allison – 2500HS	Allison – 2500RDS
	6-speed, double OD rated to 660 lb.-ft. torque, w/Fuel Sense + NAS	
<b>CHASSIS FRAME</b>	Assembled Width	34 in. (864 mm)
	Dimensions (web/flange)	10.24 x 2.75 in. (260 x 70 mm)
	Thickness	0.276 in. (7 mm)
	Yield Strength	110k PSI
	RBM	1.37m lb.-in.
<b>FRONT AXLE</b>	Axle Type (Meritor®)	MFS-10
	GAWR (lbs.)	10,000
	Brake Size (in.)	16.5 x 5
	Suspension Taper-leaf	Mack Taper-leaf
	Capacity (lbs.)	10,000
	Shock Absorbers	Telescopic type

<b>CAB</b>	Steel cab with trim level
<b>Air Conditioning</b>	Standard
<b>Audio</b>	AM/FM with Bluetooth
<b>Body Builder Prep</b>	Harness and 12 pin RP140a connectors for body lighting connection
<b>Cab Lighting</b>	Interior courtesy lights (2)
<b>Cab Mirrors</b>	Black finish with integral convex mirror
<b>Cab Suspension</b>	Dual airbag cab suspension
<b>Cruise Control</b>	Standard
<b>Cup Holders</b>	Two large cup holders in console
<b>Passenger Door Window</b>	Lower door peep window with lens
<b>Power Outlets</b>	12 volt & USB
<b>Power Steering</b>	Standard
<b>Power Windows and Locks</b>	Standard
<b>Pro Dash</b>	Premium dash cluster
<b>Seat Driver</b>	High back, air suspension w/vinyl trim
<b>Seat Passenger</b>	High back, fixed base w/vinyl trim, bench seat option
<b>Steering Column</b>	Tilt and Telescopic
<b>Steering Wheel</b>	Flat-bottom steering wheel
<b>Sun Visors</b>	Driver and Passenger
<b>Brake System</b>	Bendix® Antilock Braking System Meritor S CAM Q + air brakes
<b>Parking Brake</b>	Rear axle, spring brake
<b>Air Dryer</b>	Wabco SS1200HP



<b>FUEL TANK</b>	Round 22 in., driver side, 50 gallons	<b>WHEELS</b>	Accuride™ steel disc, powder coated white wheels 8.25 x 22.5 in., offset 6.6 in.; 5-hole
	Round 22 in., driver side, 90 gallons		Accuride™ aluminum wheels 8.25 x 22.5 in., offset 6.59 in.; 10-hole
<b>DEF TANK</b>	25 liter, passenger side	<b>TIRES</b>	Front/Rear – Bridgestone® Ecopia radials, R268 11R22.5 (H) Rear Traction Option – Bridgestone® Ecopia radials, M760 11R22.5 (G)
		<b>Low Profile Option</b>	Front/Rear – Bridgestone® ED Radials, R255/70R22.5 (H) Rear Traction Option – Bridgestone® ED Radials, M726/70R22.5 (H)

REAR AXLE	STANDARD	OPTION	OPTION	OPTION	OPTION	OPTION
<b>GAWR (lb.)</b>	17,000	17,000	19,000	19,000	21,000	21,000
<b>Axle Type – Meritor</b>	MS-17-13x	MS-17-14x*	MS-19-13x	MS-19-14x*	MS-21-13x	MS-21-14x*
<b>Brake Size (in.)</b>	16.5 x 7	16.5 x 7	16.5 x 7	16.5 x 7	16.5 x 7	16.5 x 7
<b>Suspension – Taper-leaf (lb.)</b>	17,000	17,000	19,000	19,000	21,000	21,000
<b>Suspension Option (lb.)</b>	Maxlite AL190 19,000				Maxlite AL210 21,000	
<b>RA Ratio</b>		5.57	4.88**	5.29	5.83	5.86

\*14x and driver controlled differential lock, Rear axle option equipped with driver controlled differential lock.

\*\*4.88 RA ration only available with Low Profile tire option

Shaded areas indicate optional specifications.



## Warranty Summary

MD Series	
Typical Vocations	Distribution, Short Haul, Pick Up & Delivery
Axle Configuration	4 x 2
Basic Coverage	24 months/unlimited miles*
Batteries	12 months/unlimited miles*
Chassis Towing	90 days or 5,000 miles (8,047 KM), whichever occurs first*
Air Conditioning	24 months/unlimited miles – air conditioning (sealed system only)
Engine/Emissions	Warranty coverage provided by Cummins® – both EPA and CARB
Transmission	Warranty coverage provided by Allison Transmission®
Driveline, Rear/Front Steer Axle	24 month/unlimited miles*
Cab Structure and Internal Cab Corrosion	60 months/unlimited miles*
Frame Rails/Cross Members	60 months/unlimited miles*
Noise Emission	Life of the vehicle*

\*See complete warranty certificate for details



## Uptime Summary

MD Series	
Mack OneCall®	12 months
Mack ASIST	12 months
Geotab® Basic	12 months

### Purchase Options

Mack OneCall®	24-60 months, in 12-month increments
Mack ASIST	24-60 months, in 12-month increments
Geotab® Basic	24-60 months, in 12-month increments
Geotab® Pro	12-60 months, in 12-month increments

### Other Options

Allison Transmission® Upgrade	FuelSense® Premium w/Dynactive and NAS
Battery Shut Off	Under cab, passenger side
Engine Block Heater	120V-750W (0.75KW)
PTO Prep	Harness and switch kit
Cab Mirrors	Black finish with integral convex, heated and motorized
	Chrome Finish with integral convex, heated and motorized (Bull Dog Mirror)
Passenger Seat	Two-person bench seat with vinyl trim and under-seat storage
Driver and Passenger Seat Trim	Modura cloth upgrade seat upholstery
Seat Belts	Orange driver and passenger belts
Bumper/Grille	Chrome bumper and grille combination

Shaded areas indicate optional specifications.

**MACK**®

All illustrations, specifications and descriptions in this specification are based on the latest product information available at the time of this publication. The right is reserved to make changes in price, materials, equipment, design, specifications, diagrams and models, and to discontinue models of equipment at any time, without notice and without incurring any obligation whatsoever. For more information on additional options and accessories, contact Mack Trucks, Inc. ([www.macktrucks.com](http://www.macktrucks.com)).

©2024 Mack Trucks, Inc. All rights reserved. Mack, Mack and the Bulldog design, Bulldog and all other marks contained herein are registered trademarks of Mack Trucks, Inc. and/or Mack Trucks, Inc. affiliated companies. All other marks contained herein are the property of their respective owners.

**SS-OX-MD6-0324**