

**MACK**®

# Geared up for any job.

Mack *mDRIVE*™ HD Automated Manual Transmission

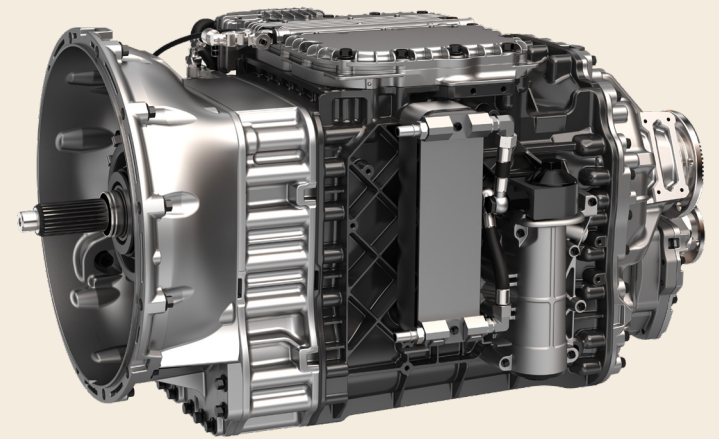

**mDRIVE HD**



# Shift your thinking.

Mack's *mDRIVE*™ HD heavy-duty automated manual transmission is standard on the Mack® Granite® and is an option for the Mack Pinnacle™ and TerraPro® models. Available as a 12-speed with two optional creeper gears plus multi-speed reverse gears, *mDRIVE* HD allows you to slow it down for jobs that require extra precision or speed it up to take on your roughest work.

Because *mDRIVE* HD is automated, it's easier to work with than traditional manual transmissions. Drivers don't have to worry about shifting gears—they're more rested and ready to finish the job with increased focus. And with low gear ratios, drivers can more easily adapt to whatever the job demands, allowing for increased productivity and performance. When you're faced with the most challenging jobs, *mDRIVE* HD's flexibility helps you keep driving to the top.

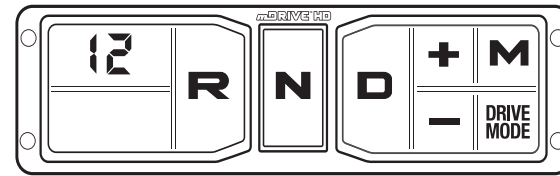

GRANITE



PINNACLE



TERRAPRO

# Designed and built to perform at the highest level in the most demanding conditions.

## Lightweight performance

Our transmissions are hundreds of pounds lighter than competitors, so you can ditch the dead weight and increase your payload.

## Works hard. Drives easy.

*mDRIVE* HD uses intelligent software and engine integration to automatically select the best gear and shift with speed and precision for an easier ride, meaning less work for drivers.

## PTO options

Power any job with ease. *mDRIVE* HD is available with eight different combinations of rear transmission-mounted PTO options and a selection of factory-installed piston and gear-driven hydraulic pump options.

---

## Auto Neutral

No sudden movements. By automatically shifting *mDRIVE* HD into neutral when the parking brake is set, Auto Neutral helps improve jobsite safety by reducing the possibility of the truck moving due to accidental throttle application.

---

## Creeper Gears

Bogged down? Throw it in creeper gear and we can walk right out. 160,000 pounds in the gravel pit with tight turns, steep grades? No problem. Get it up the grade and be on your way.

---

## Grade Gripper

With Grade Gripper, uphill is no longer a battle. When your truck's on an incline it maintains pressure for three seconds after the brake pedal is released so there's no rolling backwards.

---

## MackCellerator

Need a burst of speed? This kickdown feature downshifts the transmission when the driver pushes the accelerator to the floor. MackCellerator lets you maintain full control by keeping your hands on the wheel and eyes on the road as you navigate heavy traffic or merge onto highways.

## One-stop service

Forget the additional time or hassle of third-party repairs. *mDRIVE* HD is serviced in Mack's industry-leading, coast-to-coast dealer network and supported by our comprehensive Uptime Solutions.

## Enhanced Construction Shift

Heavy-duty construction jobs demand more aggressive shifting. Enhanced Construction Shift maximizes gradeability and improves starting and shifting on rough terrain.

## Heavy Haul Shift

Meet Mack's most assertive shift strategy yet. Designed for the trucks that shoulder large loads over 160,000 GCW, Heavy Haul Shift offers even more performance-oriented shift points and less skip shifting.

---

## MaxxBreak

MaxxBreak keeps the engine in its optimum RPM range to maximize the additional braking power provided by the engine for enhanced braking performance and control, even on the steepest of descents.

---

## Power Launch

Whether your truck is frozen to the ground or stuck in the mud, Power Launch uses the full torque of your engine to get you out of any bind. Get moving again, no matter the conditions.<sup>1</sup>

---

## Rock Free

Don't let troublesome terrain keep you down. When the truck gets stuck or in situations where wheel spin occurs, *mDRIVE* HD has the ability to rock the vehicle back and forth to break you free.<sup>1</sup>

---

## Rolling Start

Smooth paving starts here. Rolling start allows drivers to shift the transmission into drive without pressing the truck's service brakes, a function handy for paving applications. Pull away from the paver in one smooth motion without creating bumps or lumps in the paving surface.<sup>1</sup>

<sup>1</sup> Requires Mack Premium shifter package

# We invented the integrated powertrain.

Mack's *mDRIVE* HD continues over a century of setting the gold standard for powertrain integration. This transmission was designed from the start to work seamlessly with your Mack engine and axles for improved fuel efficiency, increased uptime and lower total cost of ownership.

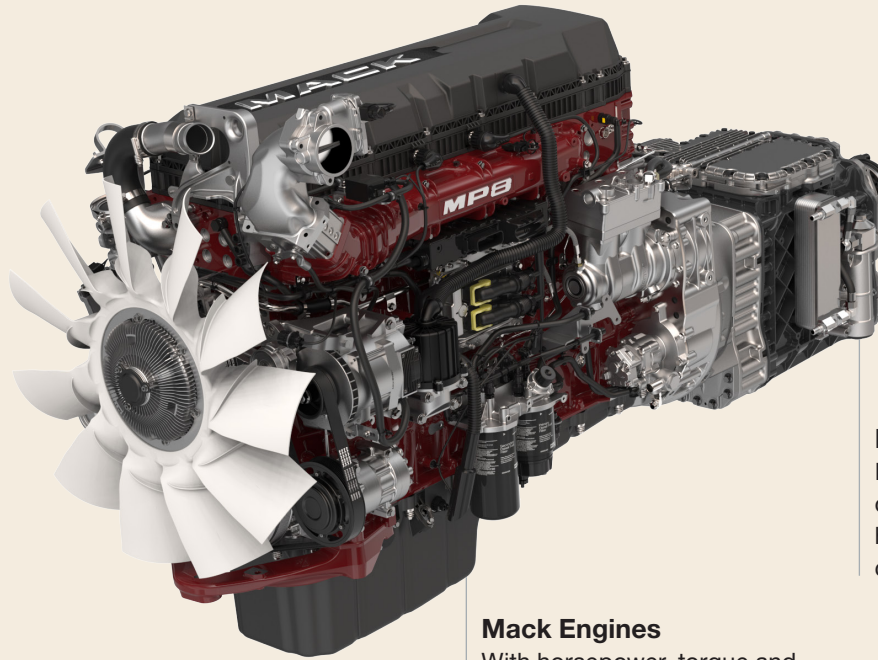

## **Mack Engines**

With horsepower, torque and great fuel economy, MP engines power through the job.

## **Mack Transmissions**

Mack's *mDRIVE* HD transmission is designed and built to perform at the highest level in the most demanding conditions.

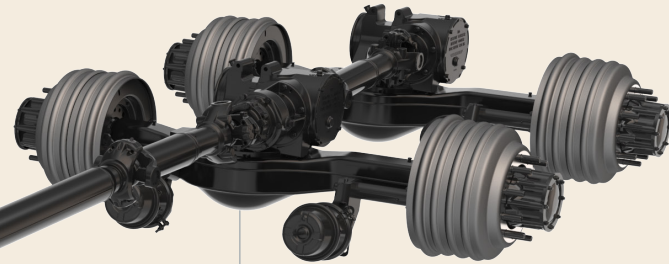

## **Mack Axles**

Mack axles and carriers are engineered to handle heavy hauls and the rigors of the jobsite.